



(19) **United States**

(12) **Patent Application Publication**

**Redon**

(10) **Pub. No.: US 2007/0170230 A1**

(43) **Pub. Date: Jul. 26, 2007**

(54) **DEVICE AND ADVERTISING METHOD FOR POPUP PACKAGING**

(52) **U.S. Cl. .... 229/116**

(76) **Inventor: Olivier Redon, Portola Valley, CA (US)**

(57) **ABSTRACT**

Correspondence Address:  
**BAY AREA INTELLECTUAL PROPERTY GROUP, LLC**  
**PO BOX 210459**  
**SAN FRANCISCO, CA 94121-0459 (US)**

A packaging device for a flat object is shown. The device is constructed from a flat material. The material has a central folding line, two rectangular areas symmetric with respect to the central folding line. The rectangular areas each have a triangular area formed by folding lines. Sidewall section areas are formed adjacent the triangles. Object support flaps adjacent to each of the sidewall section areas are formed. The support flaps each having a right angle cut delineating a flexing sub-triangle region. The device has a folded position where the support flaps are folded inward and the material is folded along the central folding line such that the support flaps are contained between the rectangular areas. Opposing sub-triangle regions are attached providing a storage space for the object. The device has an unfolded position where sidewall sections fold inward forming a 3D tetrahedron shape and the object can be displayed.

(21) **Appl. No.: 11/558,923**

(22) **Filed: Nov. 12, 2006**

**Related U.S. Application Data**

(60) **Provisional application No. 60/738,143, filed on Nov. 17, 2005.**

**Publication Classification**

(51) **Int. Cl. B65D 5/00 (2006.01)**

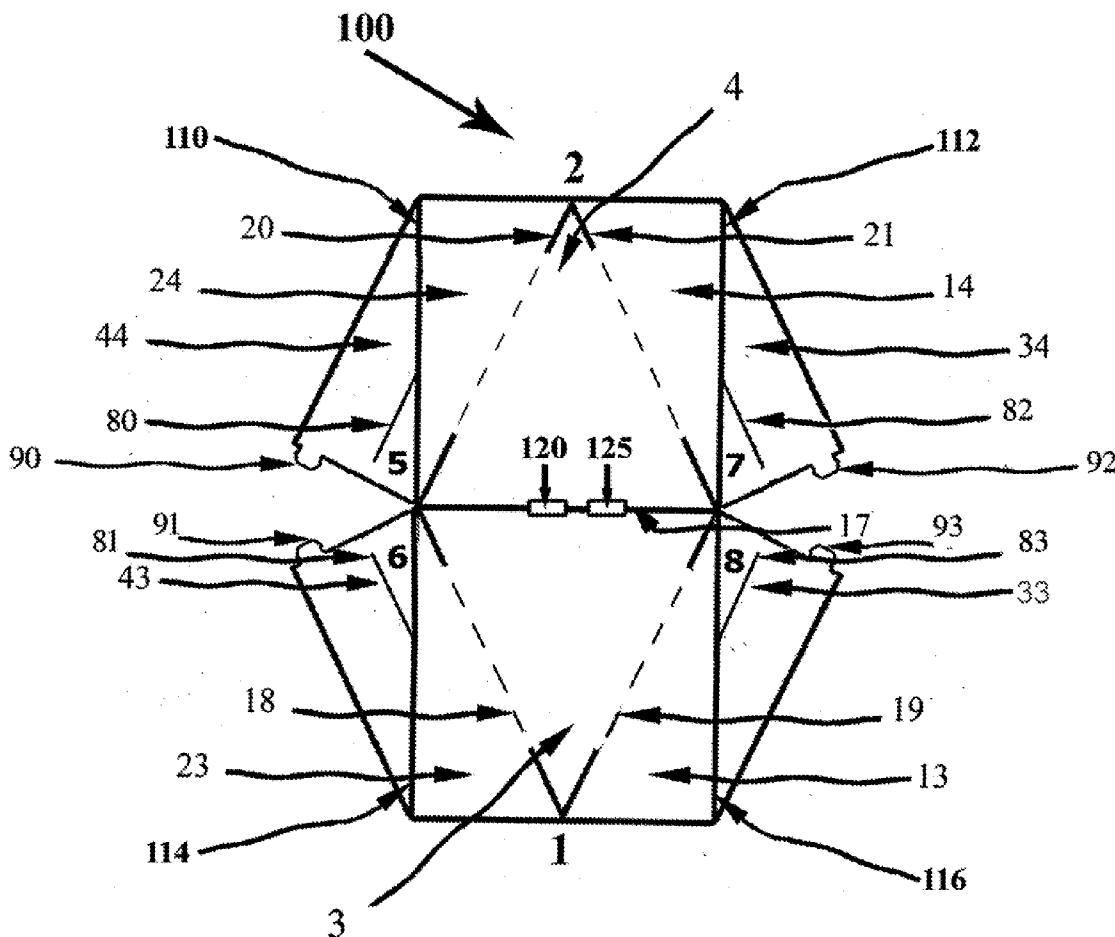

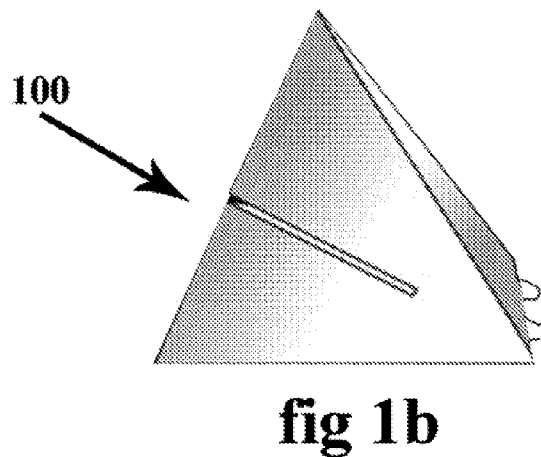
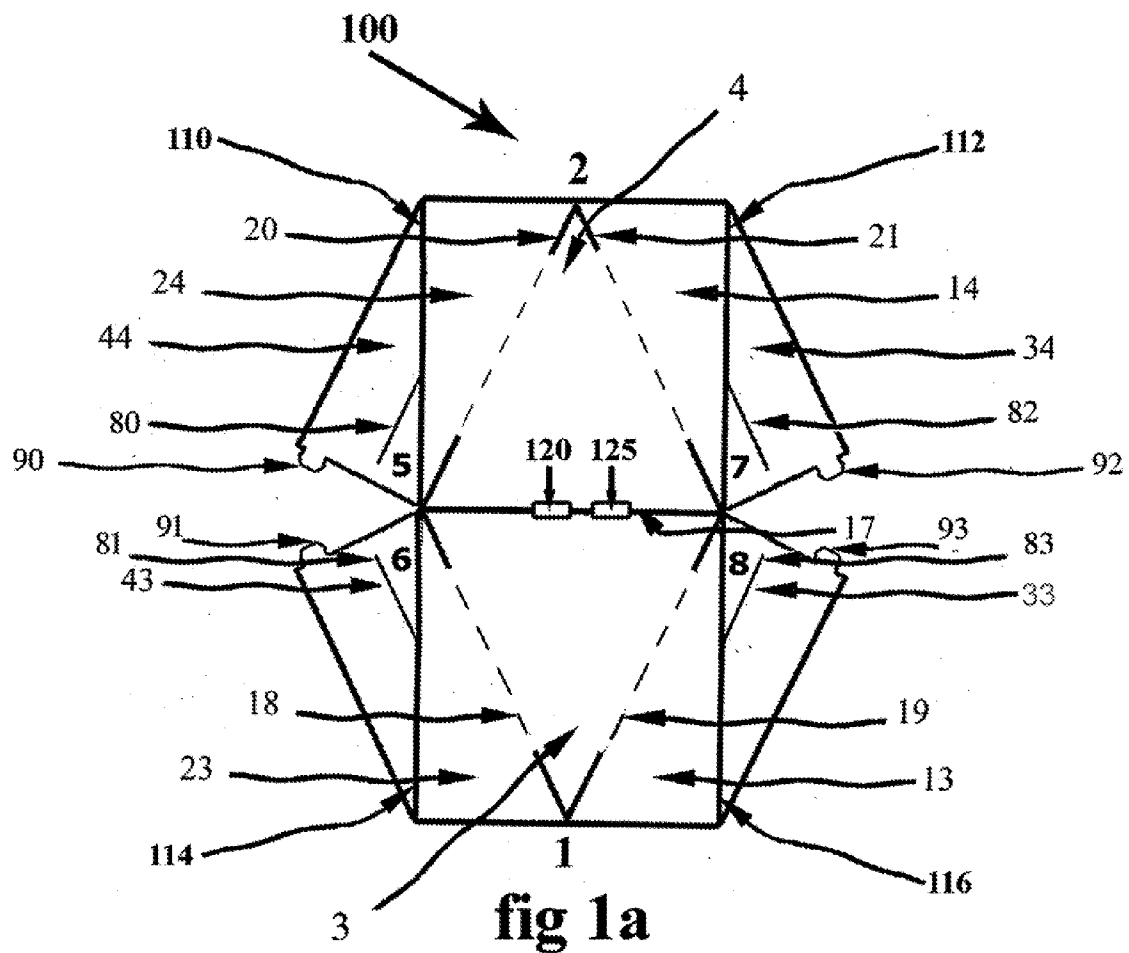

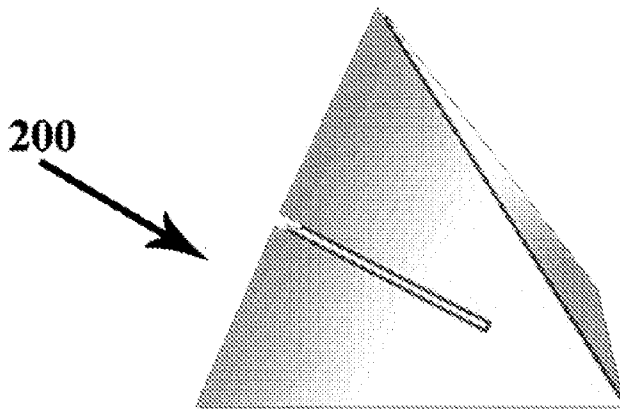
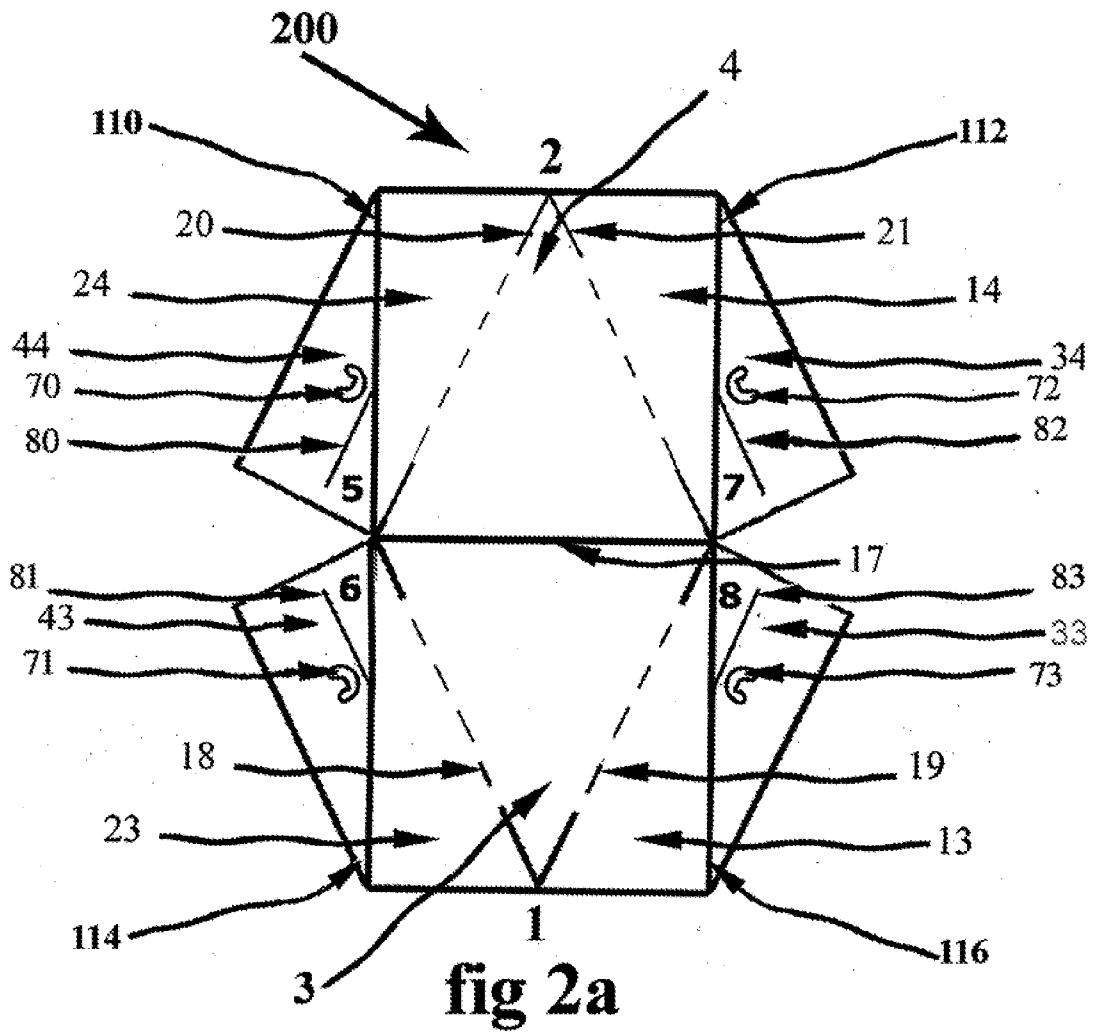

**fig 2b**

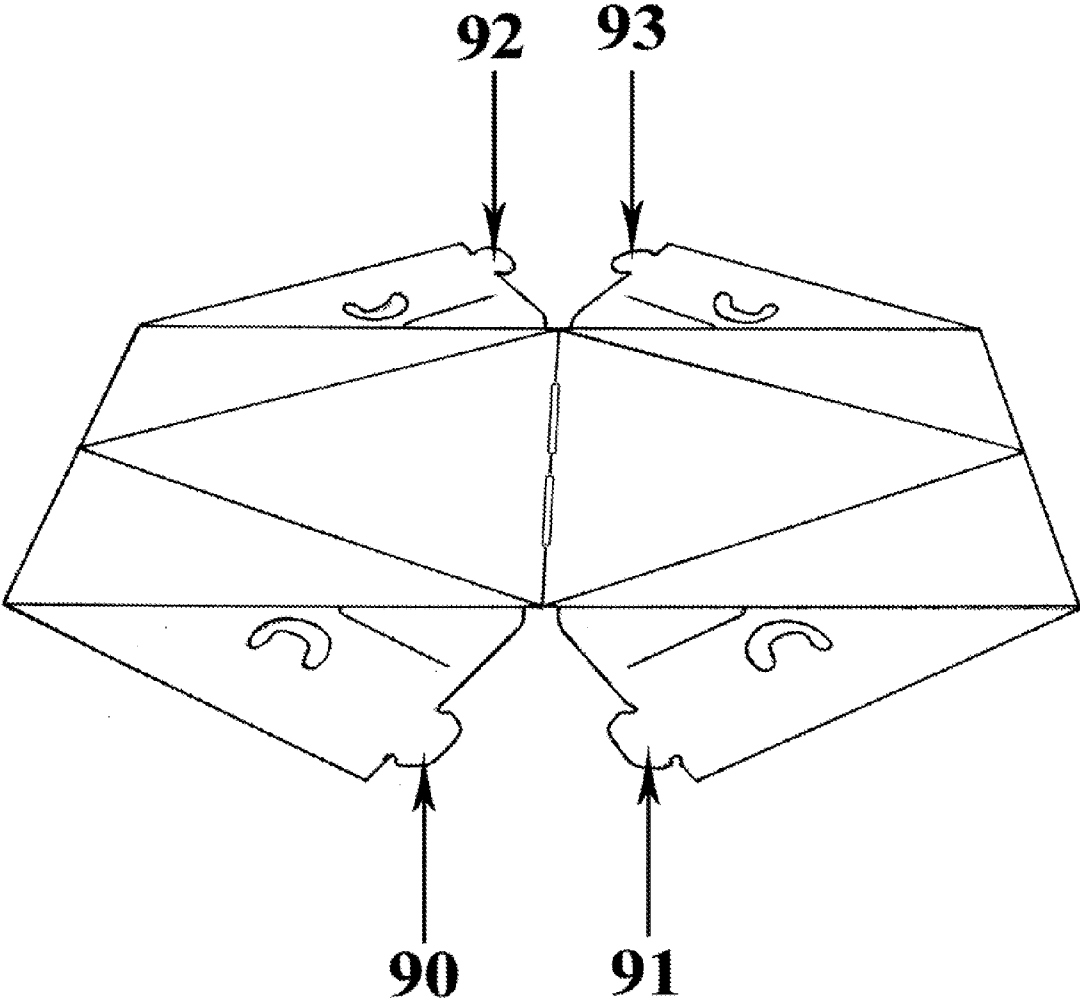

FIG 3

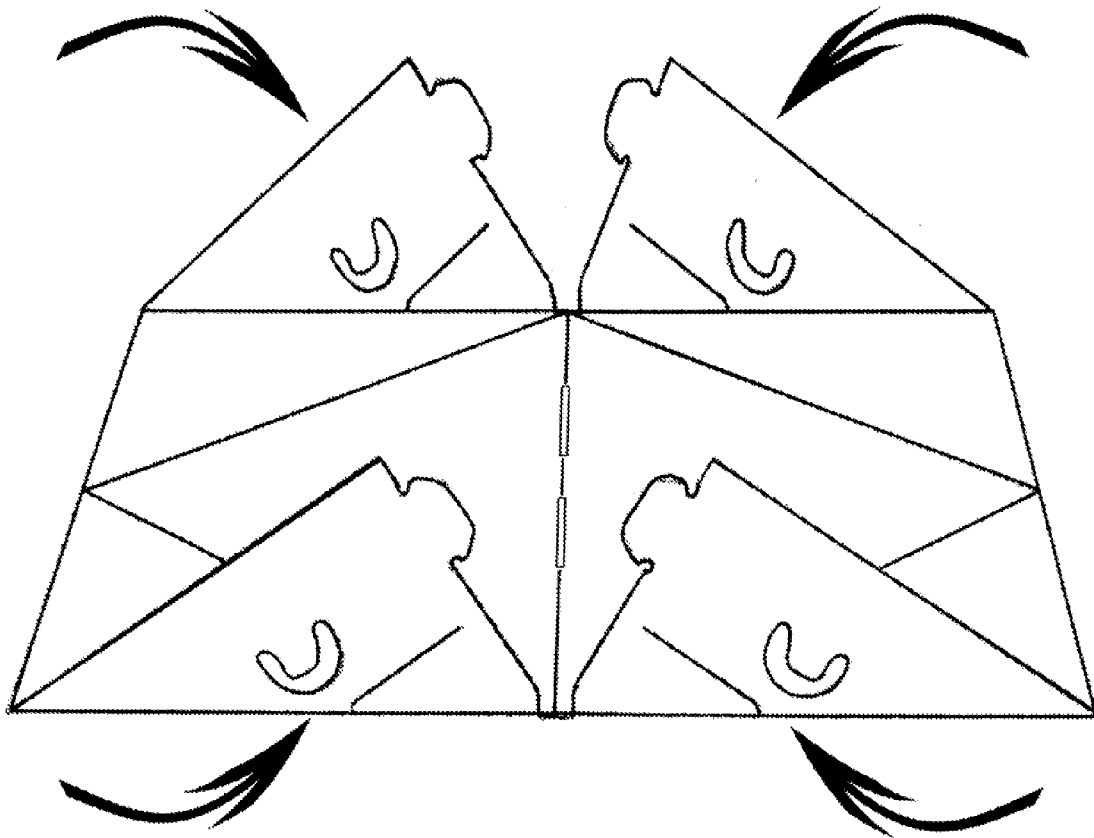
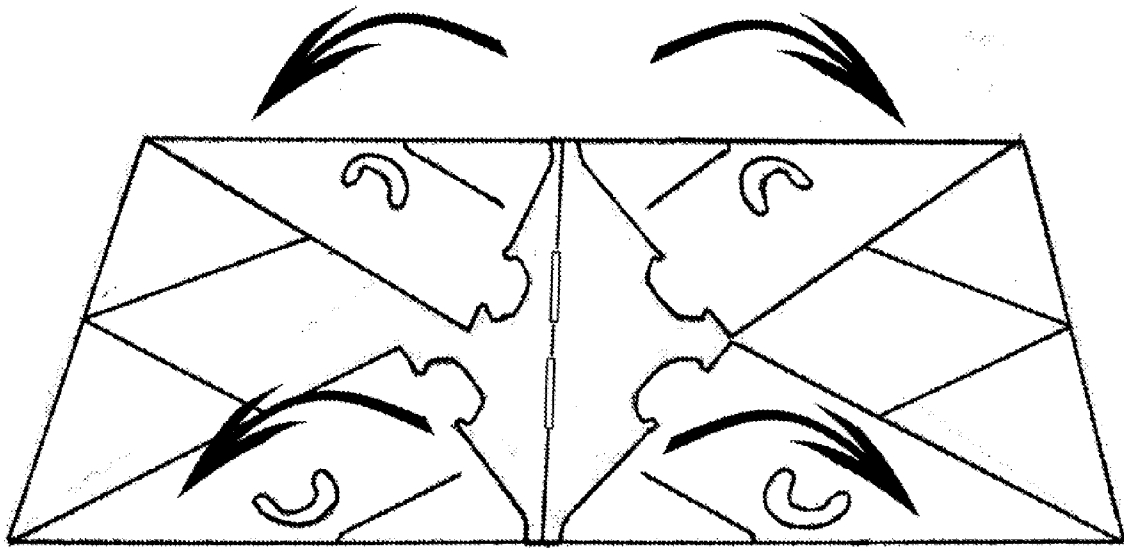
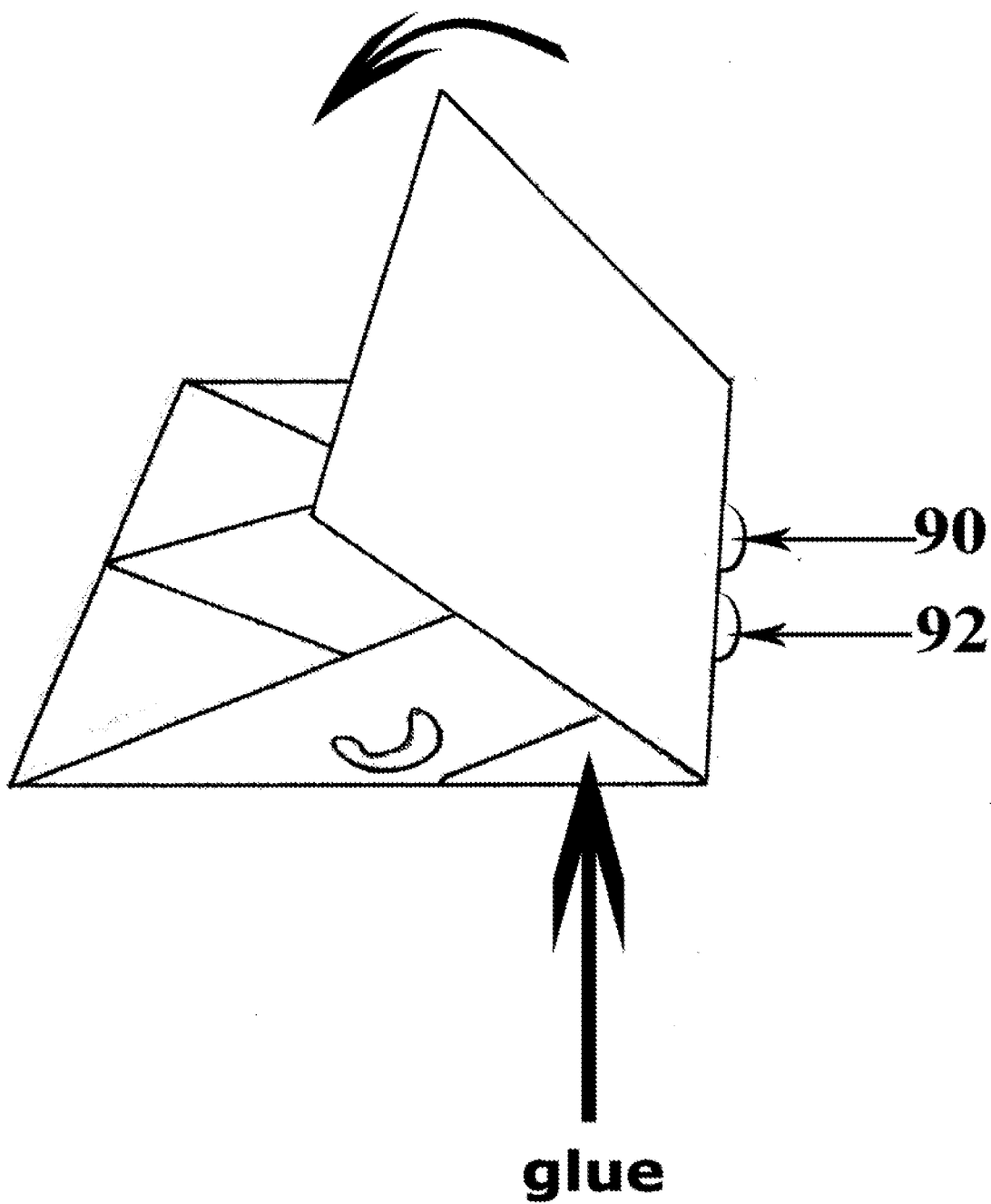

FIG 4



**FIG 5**



**fig 6a**

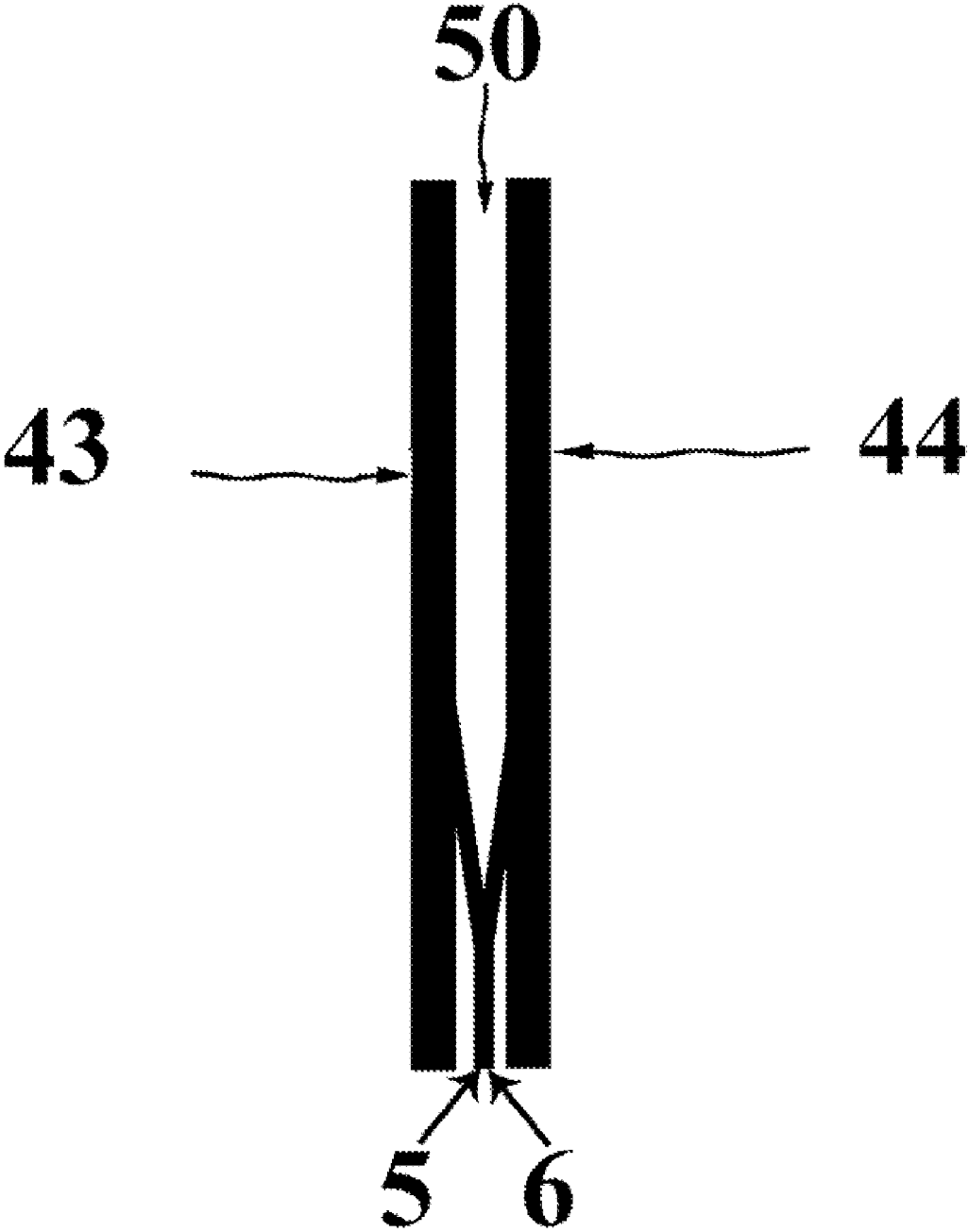

fig 6b

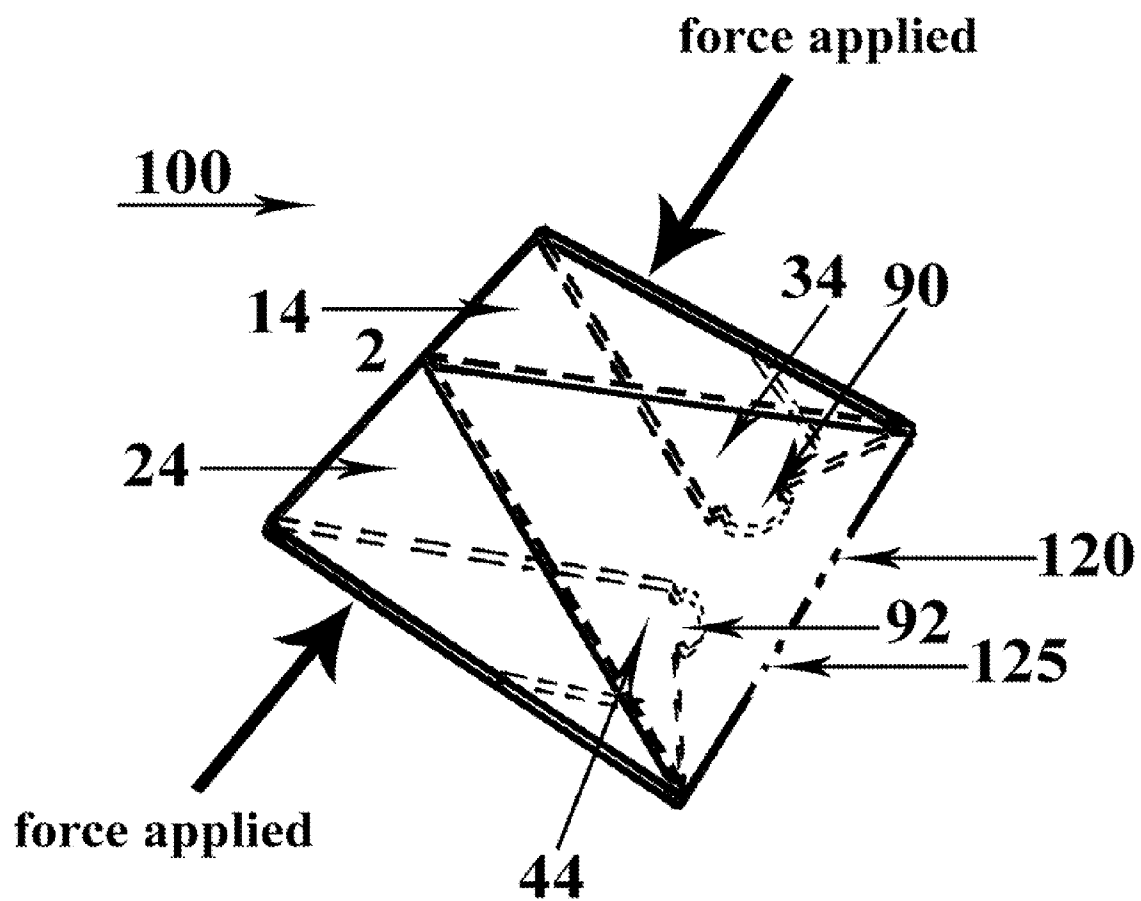

FIG 7a

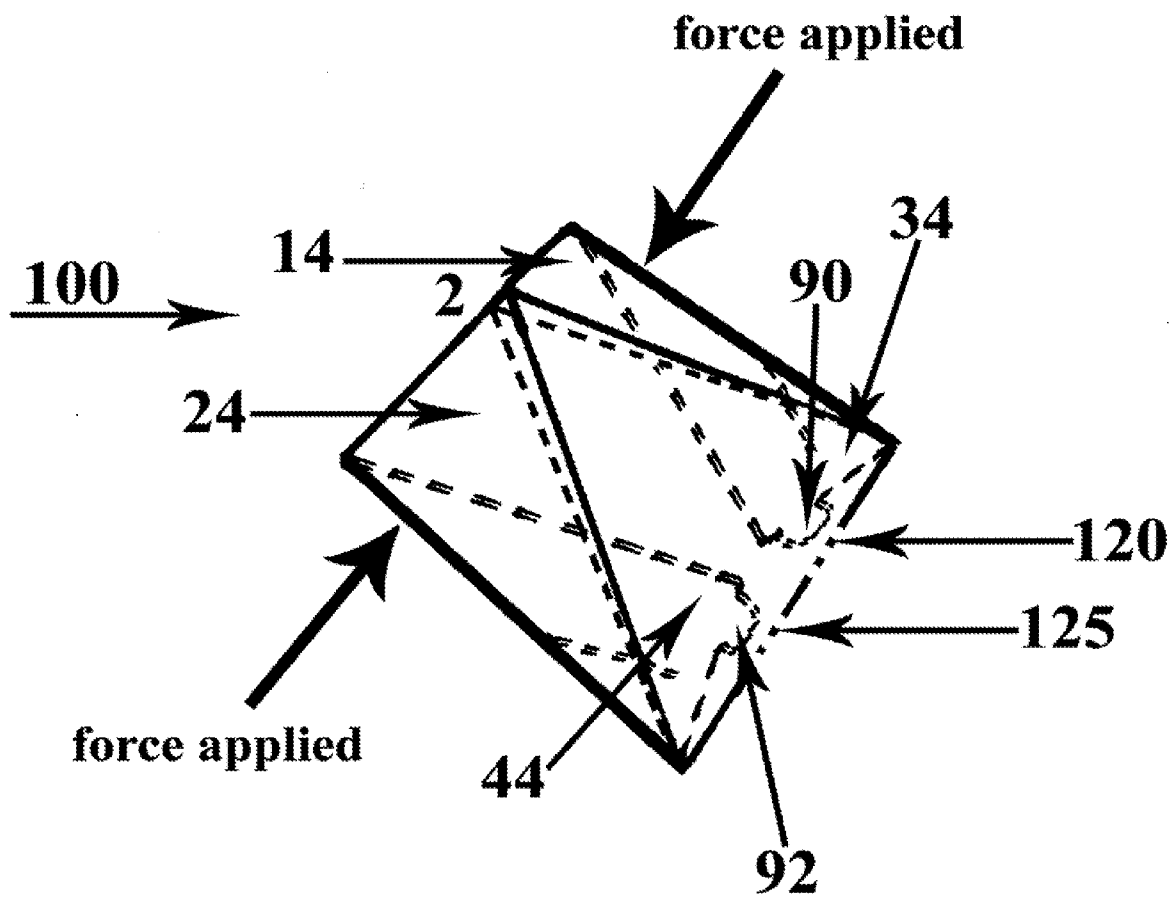

FIG 7 b

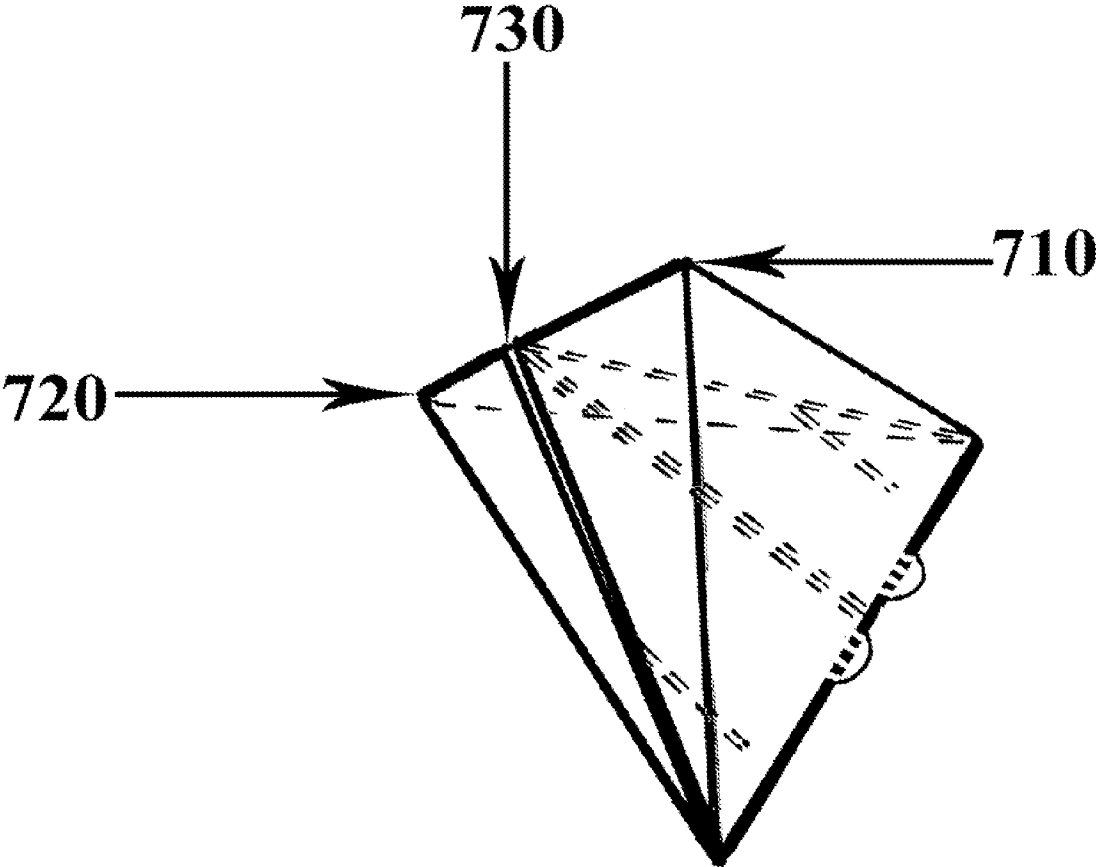
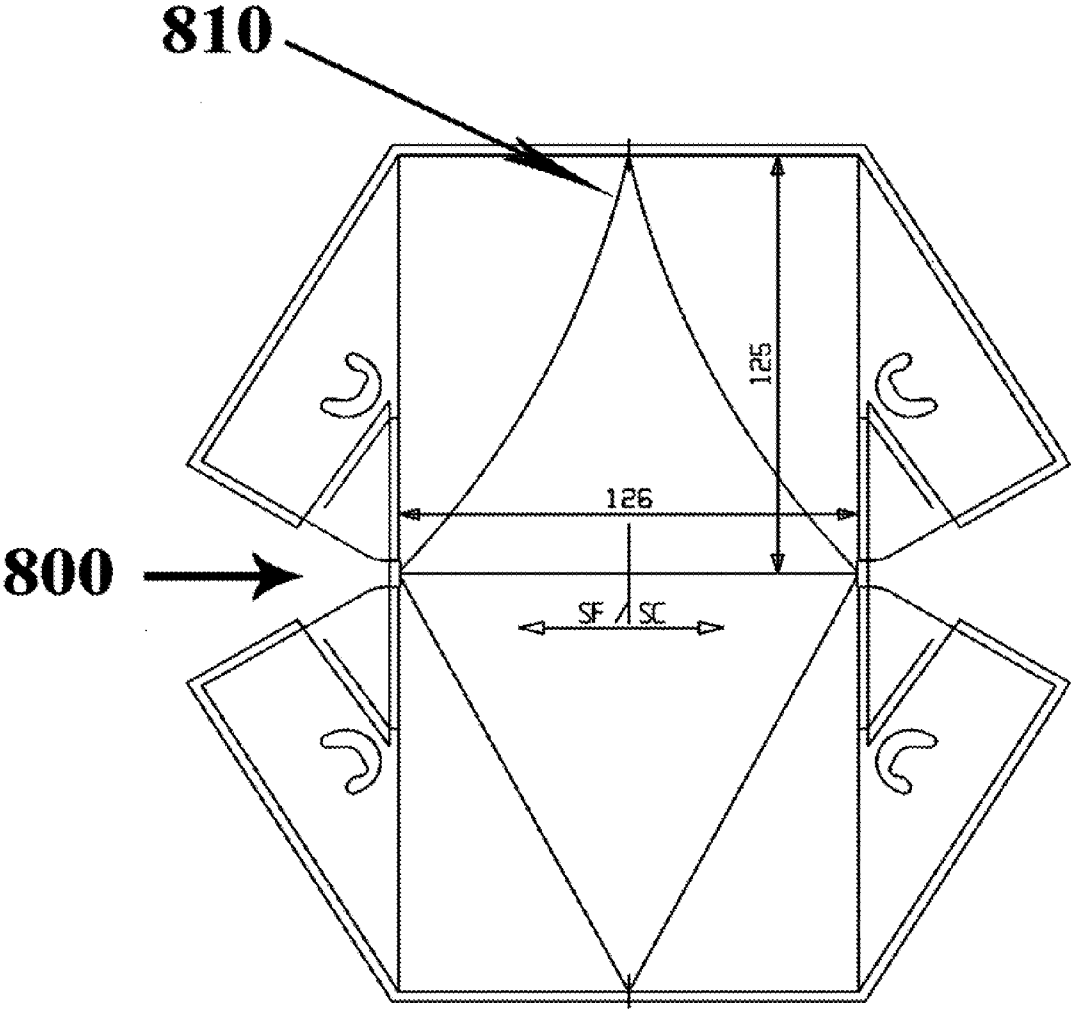
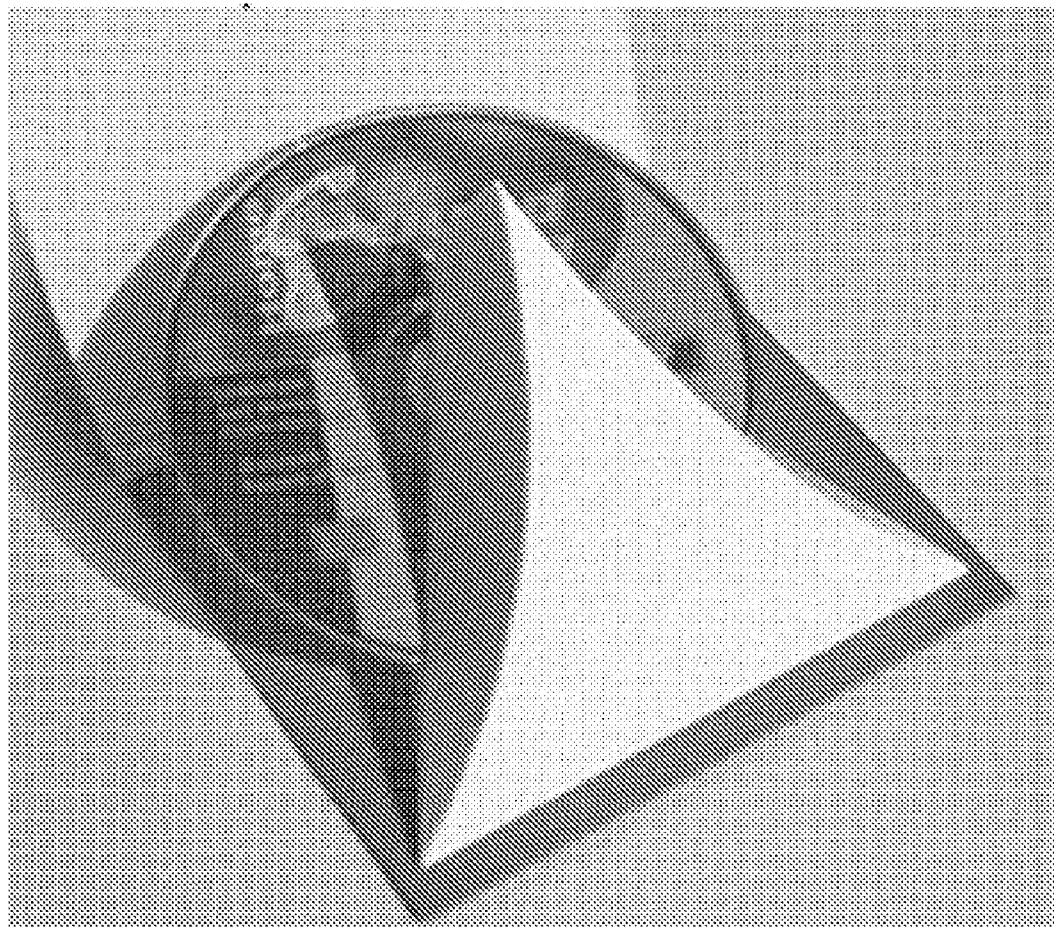

FIG 7 c



**FIG 8 a**



**FIG 8 b**

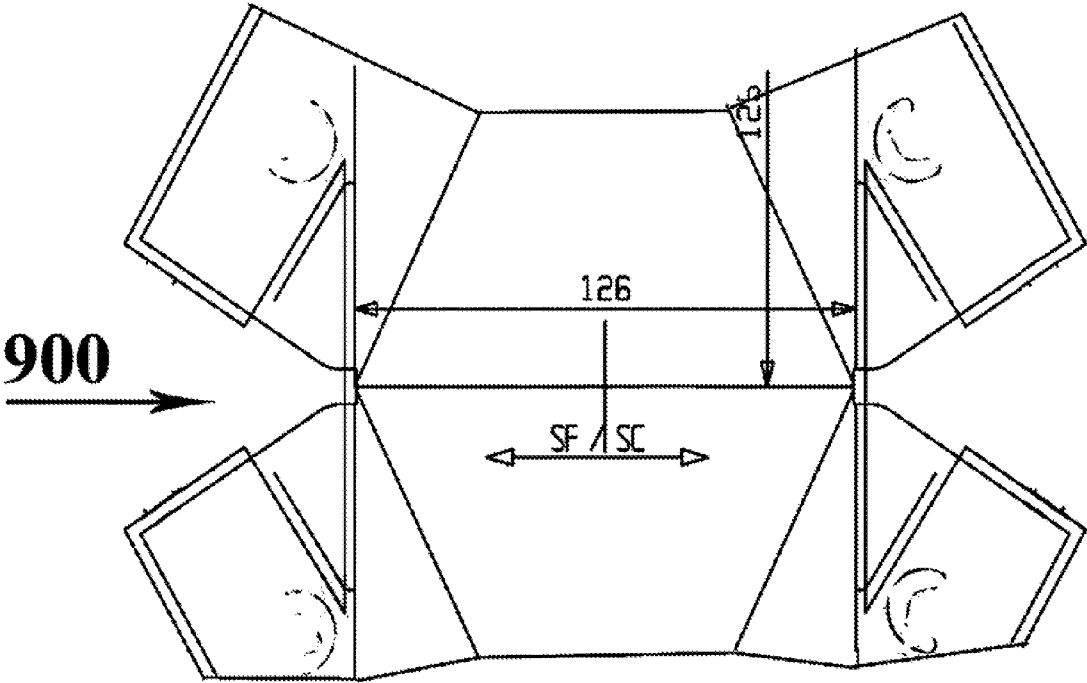
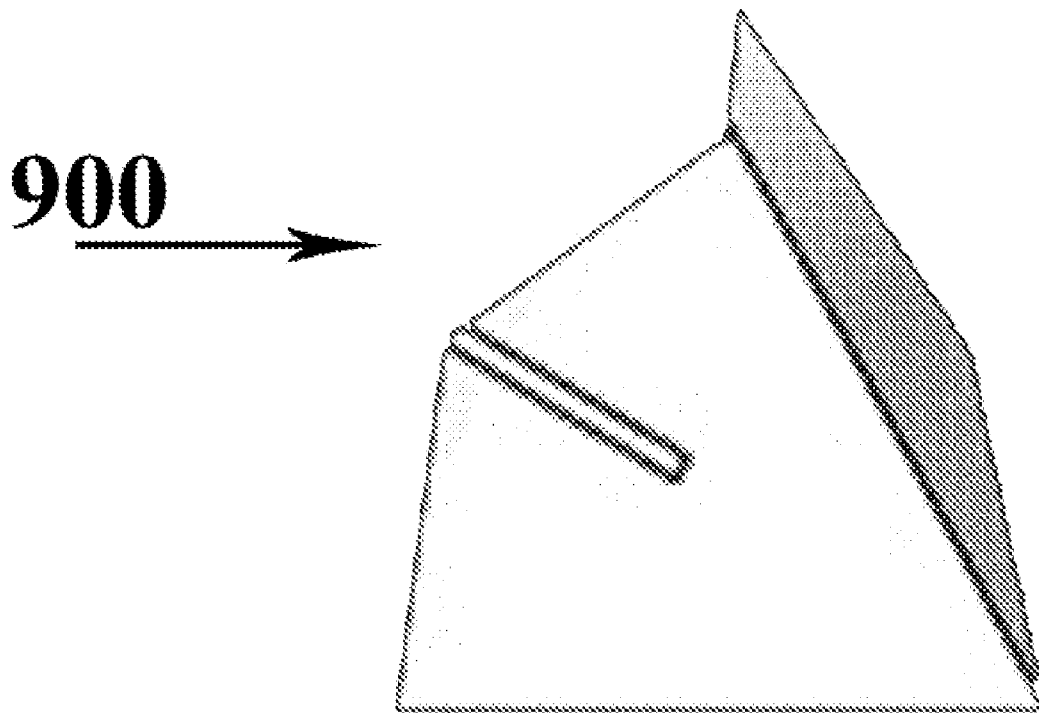
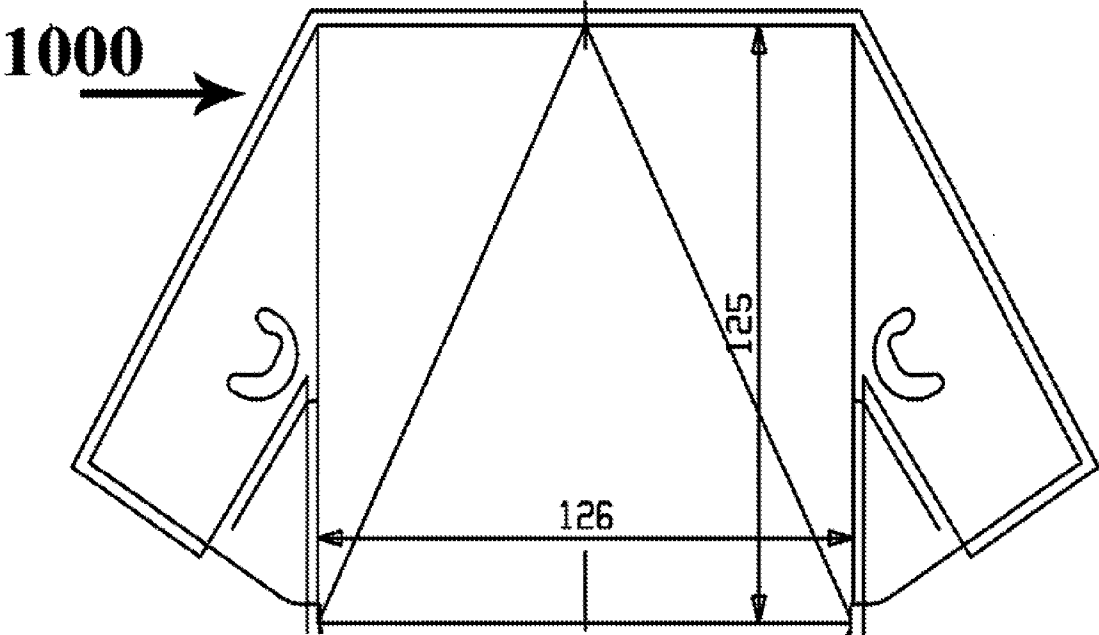

FIG 9a

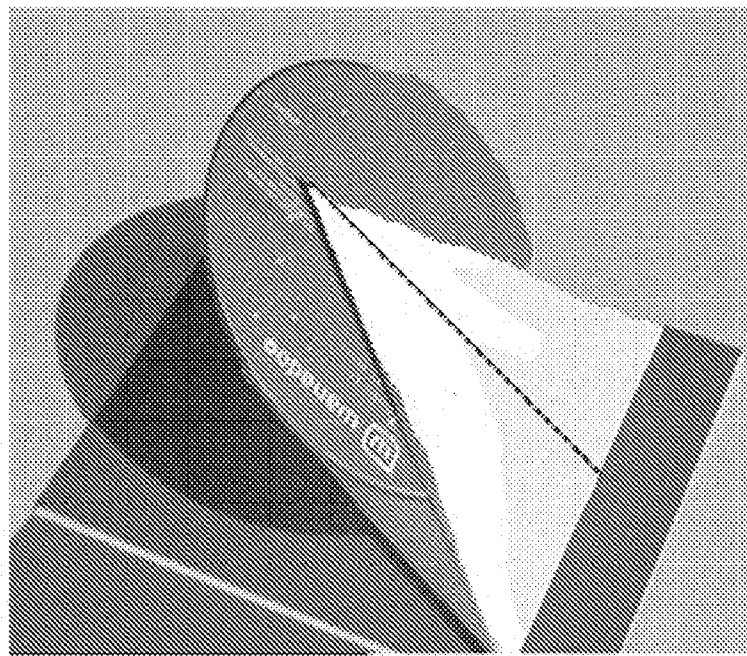

**FIG 9b**



**FIG 10 a**

**1000** →



**fig 10b**

**1000** →

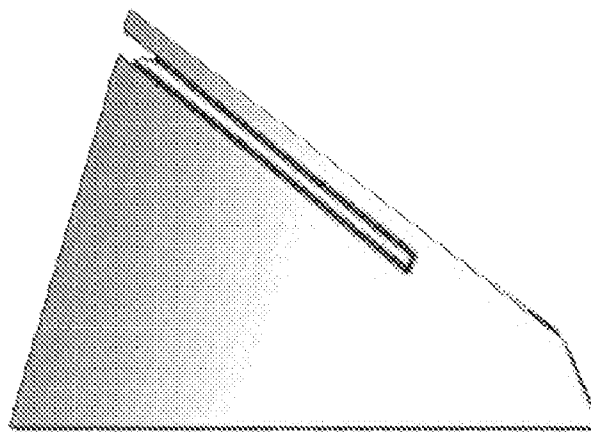

**fig 10c**

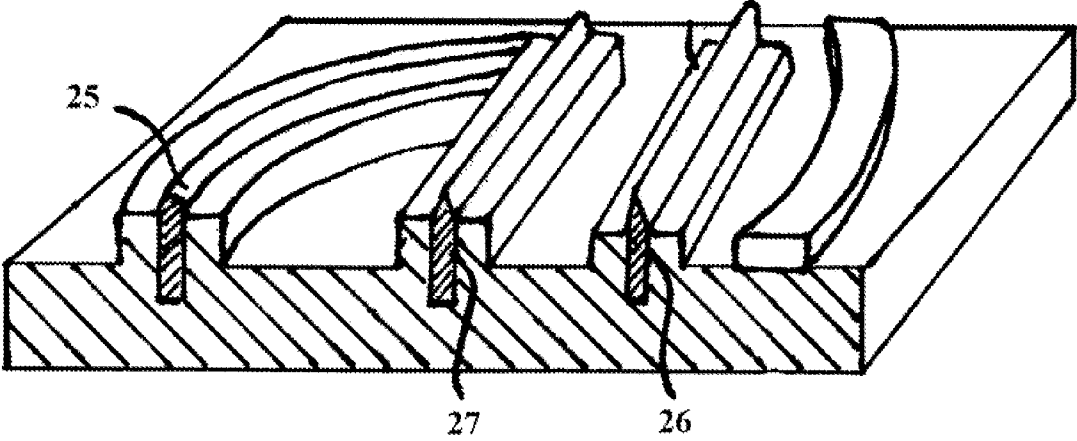

fig 11

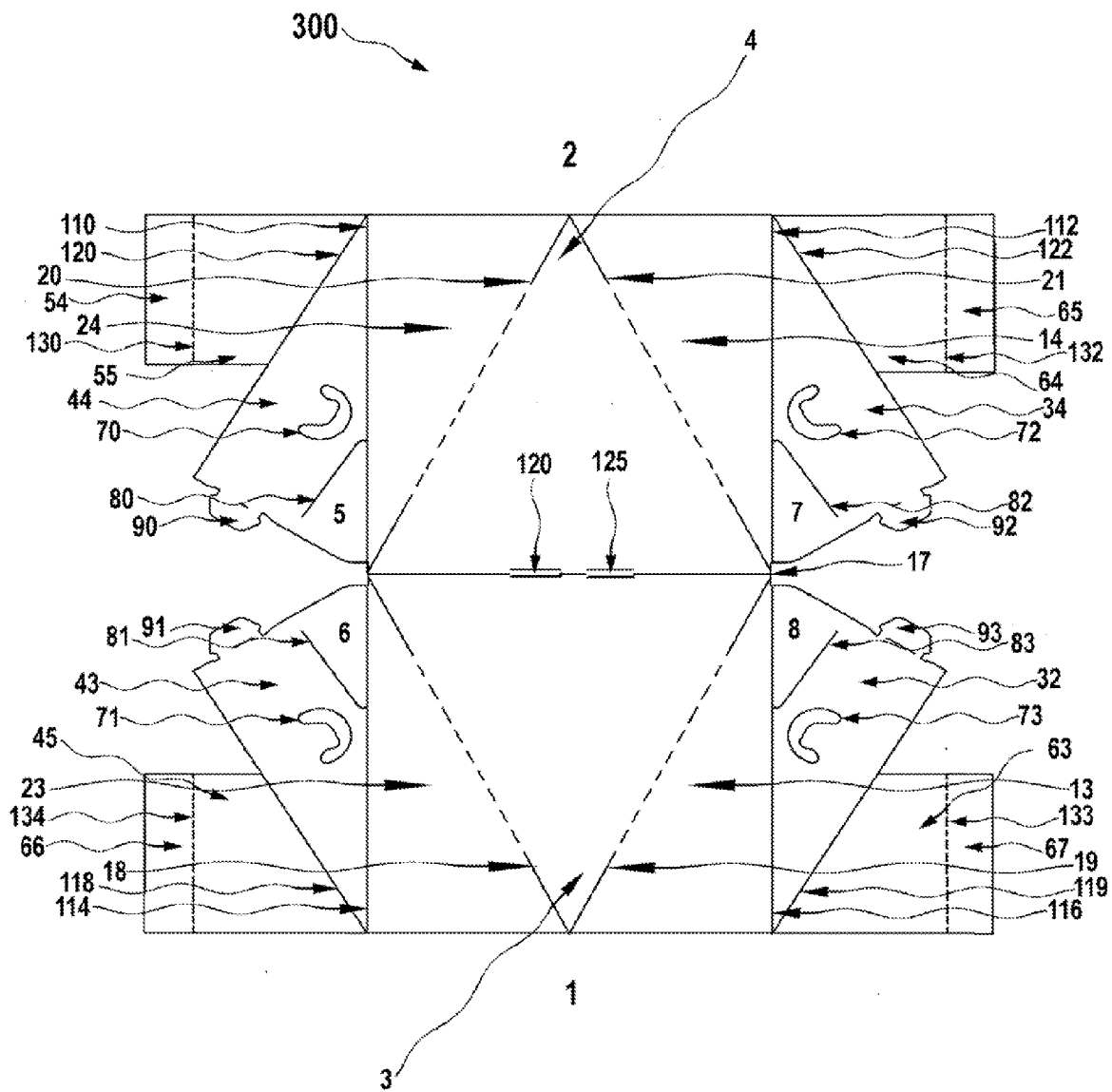

Figure 12

**DEVICE AND ADVERTISING METHOD FOR POPUP PACKAGING**

**CROSS-REFERENCE TO RELATED APPLICATIONS**

[0001] The present Utility patent application claims priority benefit of the U.S. provisional application for patent No. 60/738,143 filed on Nov. 17, 2005 under 35 U.S.C. 119(e). The contents of this related provisional application are incorporated herein by reference.

**FIELD OF THE INVENTION**

[0002] The present invention relates generally to dynamic and aesthetic packaging. More particularly, the invention relates to packaging means capable of storing relatively flat materials in an initial collapsed, flat configuration, which is expandable into a three dimensional geometric shape.

**BACKGROUND OF THE INVENTION**

[0003] Inventor's own initial effort to create a device for the packaging and display of computer discs is shown and described in French patent #2865121. However, after significant research and implementation efforts, it was discovered that this initial attempt suffers from many practical implementation and cost issues that are not obvious to overcome. It is also remarked that this French patent fails to teach methods to use the disc packaging device beyond placing the device "on the second, or third cover of a book, in cases where the disc contents complements the book."

[0004] The advertising industry is always searching for new and exciting ways to grab the attention and interest of consumers. Magazines, for example, attempt to insert flyers, or scented postcards, scratch and win, scratch and sniff, etc. Many companies sell products that use computer discs (e.g., Internet Service Providers (ISP), software applications, etc.) to deploy, advertise or otherwise present their product to the consumer. Known methods of delivering computer discs to the end consumer lack an engaging advertising presentation and/or messaging means.

[0005] In view of the foregoing, there is a need for improved techniques for manufacturing a dynamic computer disc display and enabling a multiplicity of advertising modes therewith.

**SUMMARY OF THE INVENTION**

[0006] To achieve the forgoing and other objects and in accordance with the purpose of the invention, a variety of popup devices are shown. Also methods for advertising/messaging using the popup devices are described.

[0007] In one embodiment, a packaging device for a flat object is shown. The packaging device comprises a flat construction material, the construction material comprising a central folding line, two rectangular areas adjacent to and symmetric with respect to the central folding line, the rectangular areas formed by the central folding line, perpendicular folding lines perpendicular to the central folding line and opposing sides opposing the central folding line, the rectangular areas each having a triangular area formed by the central folding line and triangle folding lines from corners of the rectangular areas to a point on the opposing side. Sidewall section areas are formed by the perpendicular

folding lines, the opposing sides, and the triangle folding lines. An object support flap adjacent to each of the sidewall section areas is formed. The object support flaps having right triangular shapes with hypotenuses on respective perpendicular folding lines, the object support flaps each having a right angle cut with respect to and starting near to the base of the object support flaps and ending near or at the respective perpendicular fold lines, thereby delineating a flexing sub-triangle region. The packing device has a folded position wherein the object support flaps are folded inward along the perpendicular folding lines and the material is folded along the central folding line such that the object support flaps are contained between the rectangular areas. An attachment means attaches opposing sub-triangle regions in the folded position, the attaching providing a storage space for the flat object. The packaging device has an unfolded position wherein separation forces separating the rectangular areas fold the sidewall sections inward forming sidewalls of a 3D tetrahedron shape and the flat object can be displayed.

[0008] In another embodiment, the object support flaps include locking protrusions on the base and approximate to the right angle, and the central fold line includes slots to receive the locking protrusions in the unfolded position.

[0009] In yet another embodiment, the object support flaps include elastic attachment members for attaching an elastic mechanism between object support flaps on the same side of the central folding line.

[0010] In a further embodiment, at least one of the triangular areas is formed from inwardly arcing triangle folding lines.

[0011] In yet another embodiment, communication indicia is printed on surfaces of the construction material that are visible in the folded position and the unfolded position.

[0012] In still another embodiment, the packaging device is stored for transportation in an outer casing.

[0013] In another embodiment, the construction material includes trapezoidal areas adjacent each of the object support flaps. The trapezoidal areas are formed by extensions of the opposing sides, edges perpendicular to the extensions, and folding lines on a portion of legs of the object support flaps. The trapezoidal areas each have a sub-rectangle area formed by a folding line parallel to the edge. A second attachment means for attaches opposing sub-rectangle areas in the folded position. The attaching provides a sleeve for aiding in insertion of the flat object into the storage space.

[0014] In a further embodiment, a packaging device for a flat object is described. The packaging device comprises a flat construction material. The construction material comprising a central folding line, two polygon areas adjacent to and symmetric with respect to the central folding line, the polygon areas formed by the central folding line, perpendicular folding lines perpendicular to the central folding line and opposing sides opposing the central folding line, the polygon areas each having a sub-polygon area formed by the central folding line and polygon folding lines from corners of the polygon areas on the central line to the opposing sides, sidewall section areas formed by the perpendicular folding lines, the opposing sides and the polygon folding lines; and object support flaps having polygonal shapes with one side on the perpendicular folding line, the object support flaps

each having a right angle cut with respect to and starting near to the base of the object support flaps and ending near or at the respective perpendicular fold lines, thereby delineating a flexing sub-triangle region. The packing device has a folded position wherein the object support flaps are folded inward along the perpendicular folding lines and the material is folded along the central folding line such that the object support flaps are contained between the polygon areas. An attachment means for attaches opposing sub-triangle regions in the folded position. The attaching provides a storage space for the flat object. The packing device has an unfolded position wherein separation forces separating the polygon areas fold the sidewall sections inward forming sidewalls of a 3D polyhedron shape and the flat object is displayed.

[0015] In yet a further embodiment, a packaging device for a flat object is described. The packing device comprising a flat construction material means for creating fold lines, scores, and cuts on a flat construction material, a folding means for folding the construction material into a folded position, an attachment means for attaching parts of the construction material in the folded position, and an unfolding means for unfolding the construction material into an unfolded 3D position.

[0016] In still another embodiment, a method for making a packing device for a flat object is described. The method comprising the steps of using a tool means for creating fold lines, scores, and cuts on a flat construction material, using a folding means for folding the construction material into a folded position, using an attachment means for attaching parts of the construction material in the folded position wherein a storage space is created for the flat object and the construction material can be unfolded into a 3D object to present the flat object.

[0017] In another embodiment, a method of advertising/messaging comprising the step of imprinting visible indicia upon the packaging device is described, the indicia being for use in communicating a message to a user of the packaging device.

[0018] In a further embodiment, the method of advertising/messaging further comprising the step of inserting the flat object for presentation to the user into the storage space of the packaging device.

[0019] In another embodiment of the method of advertising/messaging, the packaging device is stored in an outer casing for transportation to the user.

[0020] In yet another embodiment, the method of advertising/messaging further comprising the step of placing the packaging device, in the folded position, within an advertising/messaging medium intended for use by the user, whereby in the course of the user normally accessing the advertising/messaging medium, the packaging device is presented to the user.

[0021] In still another embodiment, the method of advertising/messaging further comprises the step of configuring the advertising/messaging medium to cooperate with the packaging device to unfold into the unfolded position so as to present the flat object to the user upon accessing a portion of the advertising/messaging medium where the packaging device is located.

[0022] In yet another embodiment of the method of advertising/messaging, the advertising/messaging medium is a printed publication and the packaging device is inserted in between pages thereof.

[0023] In a further embodiment of the method of advertising/messaging, the packaging device is retained on a page in the printed publication with a non damaging, relatively weak adhesive such that when the page is opened, the packaging device releases from the page by way of gravity.

[0024] Other features, advantages, and objects of the present invention will become more apparent and be more readily understood from the following detailed description, which should be read in conjunction with the accompanying drawings.

#### BRIEF DESCRIPTION OF THE DRAWINGS

[0025] The present invention is illustrated by way of example, and not by way of limitation, in the figures of the accompanying drawings and in which like reference numerals refer to similar elements and in which:

[0026] FIG. 1 illustrates a flattened plan view of an exemplary popup disc device 100, in accordance with an embodiment of the present invention;

[0027] FIG. 2 illustrates a plan view of an elastic retained popup disc device 200, in accordance with an alternate embodiment of the present invention;

[0028] FIG. 3 illustrates an exemplary side perspective view;

[0029] FIG. 4 illustrates an exemplary side perspective view when the triangular disc support flaps of the cutout template are folded inward;

[0030] FIG. 5 illustrates a flat rectangular form, shown by way of example in a side perspective view;

[0031] FIG. 6a illustrates an exemplary side perspective view of just before the step of gluing the sectioned corner of the triangular disc support flaps to thereby attach the two square halves to one another, in accordance with an embodiment of the present invention;

[0032] FIG. 6b is a side view of the popup disc device 100 after the gluing assembly step;

[0033] FIGS. 7a, b, and c illustrate successive steps towards transforming popup disc device 100 from flat mode to a 3-D mode;

[0034] FIG. 8a illustrates a flattened plan view of an exemplary arc shaped top popup disc device 800, in accordance with an alternate embodiment of the present invention;

[0035] FIG. 8b illustrates the resulting 3D shape of popup device 800;

[0036] FIG. 9a illustrates a flattened plan view of an exemplary oblique tetrahedron shaped popup disc device 900, in accordance with an alternate embodiment of the present invention;

[0037] FIG. 9b illustrates the resulting 3D shape of popup disc device 900;

[0038] FIG. 10a illustrates a flattened plan view of an exemplary polyhedron shaped popup disc device 1000, in accordance with a polyhedron embodiment of the present invention;

[0039] FIGS. 10b and 10c illustrate the resulting 3D shape of popup disc device 1000;

[0040] FIG. 11 illustrates an exemplary Industrial manufacturing tool fixture adapted to properly cut and fold the construction material to form at least one of the foregoing embodiments; and

[0041] FIG. 12 illustrates a plan view of a popup disc device, in accordance with an alternate embodiment of the present invention for enabling discs to slide easily to the back of the popup disc device.

[0042] Unless otherwise indicated illustrations in the figures are not necessarily drawn to scale.

#### DETAILED DESCRIPTION OF THE PREFERRED EMBODIMENTS

[0043] The present invention is best understood by reference to the detailed figures and description set forth herein.

[0044] Embodiments of the invention are discussed below with reference to the Figures. However, those skilled in the art will readily appreciate that the detailed description given herein with respect to these figures is for explanatory purposes as the invention extends beyond these limited embodiments. For example, it should be appreciated that those skilled in the art will, in light of the teachings of the present invention, recognized a multiplicity of alternate and suitable approaches, depending upon the needs of the particular application, to implement the functionality of any given detail described herein, beyond the particular implementation choices in the following embodiments described and shown. That is, there are numerous modifications and variations of the invention that are too numerous to be listed but that all fit within the scope of the invention. Also, singular words should be read as plural and vice versa and masculine as feminine and vice versa, where appropriate, and alternatives embodiments do not necessarily imply that the two are mutually exclusive.

[0045] It is to be understood that any exact measurements/dimensions or particular construction materials indicated herein are solely provided as examples of suitable configurations and are not intended to be limiting in any way. Depending on the needs of the particular application, those skilled in the art will readily recognize, in light of the following teachings, a multiplicity of suitable alternative implementation details.

[0046] The above cited French patent has many discovered implementation deficiencies. For example, the cutout and folds taught therein are not suitable for standard, high-speed manufacturing processes. By way of further example, this French patent, as described in its summary, requires for operability that addition triangular pieces (not shown) be glued onto and in between triangular surface areas for gluing (e.g., 54 and 64). This additional construction material and manufacturing procedure is relatively costly. This French patent also requires an elastic band to be operable. The cost and inefficiency of its required steps of gluing and implementing an elastic band are often, alone or in combination,

to be too costly and/or time consuming to be practical in many applications. In many applications it is desirable to not have a securing means (e.g., an adhesive or tape) that keeps the popup device from self opening; for example, without limitation, if unobstructed access to the disc is desired, or to avoid the cost of the securing means. It is further observed that in some applications the elastic band implementation is not suitable for many distribution modes, such as, without limitation, a magazine insert, where if an adhesive to keep the popup device closed is not used there is an inherent strong force to open it up, which would tend to undesirably open the magazine, possibly during shipping, for example. It took Inventor over one year of diligent effort after having filed the above cited French patent for Inventor to develop a novel disc popup design that overcomes the predecessor's many shortcomings. Methods of using the disc popup in Advertising are also provided.

[0047] In one aspect of the present invention, manufacturability issues are addressed that either improve production efficiency or reduce production costs when using current machines and processes to manufacture the present popup disc device on a commercial scale. Some design parameters that are addressed include, without limitation, the type of construction material used and how to cutout and fold the construction material.

[0048] A very difficult consideration in making an efficient popup disc design is to determine the optimal cutouts and folds for a given manufacturing process. The task is made especially difficult when the design must be produced on current high-speed (e.g., without limitation, 5000 units per hour) industrial machines.

[0049] FIG. 1 illustrates a flattened plan view of an exemplary popup disc device 100, in accordance with an embodiment of the present invention. As shown in the figure, popup disc device 100 is formed from square sections 1 and 2 that are preferably symmetric with respect to a central folding line 17; rectangular sections 1 and 2 further have contiguous, triangular disc support flaps 34, 44 and 33, 43, respectively. In the preferred embodiment, popup disc device 100 is cut out (e.g., stamped) of a solid piece of material, and then the desired fold lines are scored onto outside of the material as will be next described. Inscribed within rectangular sections 1 and 2 are formed triangular areas 3 and 4 by way of folding lines 18, 19, 20, and 21 such that the triangles share a common base along central folding line 17. Similarly, sidewall sections 14, 24 and 13, 23 are formed in by creating fold lines 110, 112, 114, and 116, which are located at right angles to and at the ends of central folding line 17 and extend to the opposite end of their respective rectangular sections 1 and 2. To enable an automatic locking mechanism, triangular disc support flaps 33, 43, 34, and 44 are each provided at their base with contiguous locking protrusions 90, 91, 92, and 93 that are sized to mate with locking slots 120 and 125 to make a self-locking system. As will be described in more detail below, this self-locking system avoids the need for the use of elastic bands to keep the flaps from returning to their initial flat position (as shown). In the preferred embodiment, the sidewall sections and the disc support flaps have a general triangular shape and are sized equal to one another. Triangular areas 3 and 4 are preferably symmetric with respect to central folding line 17. Rectangular sections 1 and 2 are preferably sized to cover the flat object (e.g., a computer

disc), which they are to contain when popup disc device **100** is in its flat storage mode. In the preferred embodiment, rectangular sections **1** and **2** are squares and triangular areas **3** and **4** are equilateral triangles. In the shown embodiment, the disc support flaps have right angle cuts **80**, **81**, **82** and **83** with respect to and starting near to the base of the disc support flaps and ending near or at the respective fold lines **110**, **112**, **114**, and **116**, thereby delineating a flexing sub-triangle region suitable for gluing as will be described below. In one aspect, this novel approach avoids the costly addition of protuberance on the upper surface of the disc support flaps, which are formed by folding a smaller flap as required in prior approaches.

[0050] FIG. 2 illustrates a plan view of an elastic retained popup disc device **200**, in accordance with an alternate embodiment of the present invention. The embodiment shown is very similar to that of FIG. 1, with the exception that stamped out elastic attachment members **70-71-72-73** have been configured into the triangular disc support flaps such that an elastic band (e.g., a standard rubber band) (not shown) may be easily hooked onto and between elastic attachment members **70** and **72** to pull disc support flaps **33** and **43** together when flattened, and likewise for the opposing disc support flaps **34** and **44**. In some applications, the additional inward pulling force that these elastic bands provide is desirable to provide the novelty of a self-erection force in transforming popup disc device **200** from a flat mode to a three-dimensional (3-D) mode (i.e., shape restored or popped up) and required (if the prior self locking features of the previous embodiment are not implemented) to keep the flaps from returning to their initial flat position, which modes will be described below. In some applications, more than one elastic band may be attached between the elastic attachment members to provide a stronger 3-D shape restoring force. Some alternate embodiments (not shown) may combine some or all of the present elastic band attachment members and some or all of the self locking features of the previous embodiment.

[0051] Exemplary steps for transforming the foregoing popup disc cutout template into a working device will next be described. The operation of popup disc device **100** is based upon the inward folding of the triangular disc support flaps to mate the locking protrusions with the locking slots and in so doing, erecting an elongated tetrahedron with the triangular disc support flap as one side in the plane of central folding line **17** and the sidewall section acting as an outer side section of popup disc device **100**. As shown in the exemplary side perspective view of FIG. 3, the cutout template of FIG. 1 is initially flattened out. Then, as shown in the exemplary side perspective view of FIG. 4, the triangular disc support flaps of the cutout template are folded inward to form the flat, rectangular form shown by way of example in the side perspective view of FIG. 5. FIG. 6a illustrates an exemplary side perspective view of just before the step of gluing the sectioned corner of the triangular disc support flaps to thereby attach the two square halves to one another, in accordance with an embodiment of the present invention. Shown in the FIG. 6b is a side view of the popup disc device **100** after the gluing assembly step. One aspect of cutouts **80-81-82-83**, is that if the triangular regions that they form are directly glued to the counterpart region of the opposing side (e.g., region **5** glued region **6** on the side shown), they allow a little "give" motion when separating the flaps outside of this glued region, thereby acting as an

effective spacer to provide a storage space **50** for holding an object, such as, without limitation, a computer disc. In this way, no additional construction materials or steps are needed, as is required in the prior art.

[0052] The square halves are then flattened in their "flat mode" as shown by way of example in FIG. 7a. The dashed outlines shown in the figure represent the outline of the hidden triangular disc support flaps.

[0053] FIGS. 7a, b, and c illustrate successive steps towards transforming popup disc device **100** from flat mode to a 3-D mode. As previously indicated, FIG. 7a illustrates a transparent top perspective view of popup disc device **100** in the initial flat mode. For the sake of clarity, only the top half related to rectangular section **2** of FIG. 1 is shown; however, the corresponding components of rectangular section **1** are a mirror image exactly under that shown. Attention is drawn to the orientation and distance of locking protrusions **90** and **92** from their associated locking slots **120** and **125**, respectively. As will be next described, during the process of forming the 3-D mode, locking protrusions **90** and **92** will automatically approach and properly be inserted into their associated locking slots **120** and **125**.

[0054] FIG. 7b illustrates a transparent top perspective view of popup disc device **100** after an initial left and right side forces are applied to bring those edges closer together. For the sake of clarity most enumerating labels have been removed and correspondence of structural element to FIG. 7a will be apparent. It will be appreciated that properly illustrating the dynamic 3D motion of the structure is difficult by way of static 2D drawings; however, an attempt to set forth the key aspects to understand the dynamic structural motion follows.

[0055] Depending upon the materials used, and the strength of the fold lines made, a varying amount of internal separation forces will exist within popup disc device **100** to separate (i.e., open) the upper and lower rectangular sections. As the upper and lower rectangular sections are opened, the sidewall sections are pulled inward to form sidewalls of the final 3D tetrahedron shape. Shown in the Figure is the state after partially opening popup disc device **100**, wherein the visible, upper, sidewall sections are slightly elevated above their initial flat position and triangular disc support flaps with their locking protrusions are all automatically drawn in towards their corresponding locking slots. As a an inward, side force is continually applied, the inside edge of the triangular disc support flaps meet each other (forming an equilateral triangle) and likewise do the bases of each sidewall section come into contact with its counterpart. Once triangular disc support flaps are in there final joined position, their locking protrusions are all automatically inserted into their corresponding locking slots, thereby resisting there separation towards there initial state. In this way, in many applications, the need for an elastic band to keep them in there joined state is overcome.

[0056] FIG. 7c illustrates a transparent side perspective view of popup disc device **100** transformed into its 3D mode. When pushed from the sides into place as previously described, it should be noted that throughout the opening process triangular disc support flaps simply rotate inward within the initial plane of the popup device when it was in the flat mode, and the sidewall sections are rotated from their original flat orientation to an almost vertical orientation to

form the sidewalls of the 3D shape. Once formed into the 3D mode, an upper **710** and lower **720** wedge sections are formed that resemble a tapered pie wedge with the complementary triangular disc support flaps forming an inner flat surface, the sidewall sections being the substantially vertical sides of the wedge, and the inscribed (within the original rectangular section **1** or **2**) triangular area being the outer surface of the wedge. Upper **710** and lower **720** wedge sections are free to rotate about central fold **17** (see FIG. **1**), thereby forming an adjustable disc holding gap **730**. Popup disc device **100** shown is preferably glued as shown in FIG. **6** to substantially constrain the rotation of upper **710** and lower **720** wedge sections to maintain disc holding gap **730** at a relatively constant gap width between the upper and lower triangular disc support flaps and thereby provide a relatively flexible gripping force to hold disc like objects (e.g., a compact disc, DVD, etc.) in place when slid into disc holding gap **730**. The gluing location may optionally be selected to limit how deep the disc may be inserted into disc holding gap **730**.

[**0057**] Popup disc device **100** will retain its 3D mode of operation until a downward force is applied at its topmost point, which will act to separate the triangular disc support flaps, which will reverse the foregoing opening process and thereby restore popup disc device **100** to its flat mode shown in FIG. **3**.

[**0058**] In light of the foregoing teachings, a multiplicity of 3D shapes and operating features may be readily achieved. By way of example, and not limitation, FIG. **8a** illustrates a flattened plan view of an exemplary arc shaped top popup disc device **800**, in accordance with an alternate embodiment of the present invention. This arc shaped popup disc device is similar to the embodiment shown in FIG. **1**, with some minor structural modifications to change the resulting 3D shape. For example, arc shaped fold lines **810** are instead formed to provide an inward arcing curvature in the sidewalls of the 3D shape, as illustrated by way of example in FIG. **8b**, in accordance with an embodiment of the present invention. Beyond changing the curvature of the sidewalls, the proportion of the upper and lower wedge sections may be modified to achieve a desired 3D shape. By way of further example, and not limitation, FIG. **9a** illustrates a flattened plan view of an exemplary oblique tetrahedron shaped popup disc device **900**, in accordance with an alternate embodiment of the present invention. The resulting 3D shape, is illustrated by way of example in FIG. **9b**, in accordance with an embodiment of the present invention.

[**0059**] Beyond changing the curvature of the sidewalls or the proportion of the upper and lower wedge sections, a multiplicity of polyhedral 3D shapes may be achieved beyond the foregoing tetrahedrons. By way of further example, and not limitation, FIG. **10a** illustrates a flattened plan view of an exemplary polyhedron shaped popup disc device **1000**, in accordance with a polyhedron embodiment of the present invention. The resulting 3D shape is illustrated by way of example in FIGS. **10b** and **10c**, in accordance with an embodiment of the present invention.

[**0060**] The foregoing exemplary embodiments operate on similar operating principals as that for the embodiment of FIG. **1**. Those skilled in the art, in light of the teachings of the present invention, will readily recognize a multiplicity of yet other 3D shape variations and functional features achievable depending upon the needs of the particular application.

[**0061**] Moreover, depending upon the needs of the particular application, a multiplicity of manufacturing oriented techniques and features are contemplated. Beyond the simple folding of the structural material to make fold lines as is done by conventional approaches, in the preferred embodiment of the present invention, the folding lines are enhanced by dotted, dashed, or spaced cutouts alternating with straight-line folds to facilitate the unfolding of the popup device into its 3D mode. An example, without limitation, of the present alternating cutout approach is illustrated in FIG. **2** as dashed cut lines fold lines **18-21**. In some applications, a simple surface scoring is desired, and other applications may require a cut completely through the construction material. One aspect of the present improved technique for forming fold lines is that less restoring force is generated when the popup device is in its 3D mode; hence, the need for an elastic band to keep the structure closed is greatly reduced. The depth and amount of scoring or cutting into the fold lines in many applications will depend on the amount of force or repeated use the fold lines will have to withstand without tearing or otherwise being weakened. Those skilled in the art, based upon the teachings of the present invention, will readily recognize a multiplicity of suitable alternate techniques to optimally make the fold lines depending upon the needs of the particular application.

[**0062**] A suitable construction material in for many applications of the foregoing embodiments is 270 g weight Kraft cardboard. The creation of the fold lines, scores, and cuts therein in a high-volume manufacturing process may be achieved by properly adapting specialized or conventional tools. FIG. **11** illustrates an exemplary Industrial manufacturing tool fixture adapted to properly cut and fold the construction material to form at least one of the foregoing embodiments. Shown in the Figure is a base with multiple specialized tools joined thereon. The base is made of a sufficiently solid material such as, without limitation, concrete, steel, etc. Typically, the surface work-tools are fixed into slots formed into the tool fixture base and are surrounded by support straps that are removed after the work is done.

[**0063**] A first tool is made up of raised grooves **25** with a generally rounded top. Grooves **25** are suitable for marking the surface of the construction material (e.g., cardboard) to form a folding line (e.g., lines **110**, **112**, **114**, and **116** of FIG. **1**) and does not cut into the material.

[**0064**] For cutting, a second type of tool is formed by a knife **26** or a group of such knives that implement the cutout plan of the pop-up device construction material (e.g., cardboard) and make incisions into or through the thickness of the cardboard. Knife **26** is preferably made of a relatively hard, but slightly flexible material, the rigidity of which is determined such that the knife can fully penetrate the target surface to cut it, while at the same time, the blade of the knife preferably does not become blunt quickly. Strait cuts such as, without limitation, cuts into fold lines **80-81** and **82-83** of FIGS. **1** and **2** can be made by knife **26**. Knife **26** may also be suitably configured to cut out various opening sizes as needed. The height of the various cutting knives protruding from their respective blade holding ridges on each side of the blade are adjusted such that the desired depth of cut is achieved. For example, without limitation, the relative height of the cutting/folding tips of a knife may be

configured such that it penetrates only half the thickness of a cardboard construction material.

[0065] A third type of tool, also suitable for cutting, is a half-knife 27, which is a shape edged blade preferably configured to only penetrate partway into the thickness of the pop-up device construction material (e.g., cardboard).

[0066] FIG. 12 illustrates a plan view of a popup disc device 300, in accordance with an alternate embodiment of the present invention for enabling discs to slide easily to the back of the popup disc device. FIG. 12 shows the contiguous locking protrusions 90, 91, 92, and 93 that are sized to mate with locking slots 120 and 125 to make a self-locking system in addition to the stamped out elastic attachment members 70-71-72-73 of FIG. 2. Some alternate embodiments (not shown) may combine some or all of the present elastic band attachment members and some or all of the self locking features of the previous embodiment. In the above cited French patent, with an automatic disc insertion machine, the disc could not correctly slide into the inside of the pocket of the pop-up device when closed. In this embodiment, legs (54,55), (64,65), (66,45), and (67,63) are formed adjacent to triangular disc support flaps 33, 43, 34, and 44. When the popup disc device 300 is folded, area 54 is glued to area 65 and area 66 and glued onto area 67. This forms a sleeve where the disc can slide easily to the back. Folding lines are represented by elements 120, 130, 122, 132, 118, 134, 119, and 133.

[0067] In light of the teachings of the present invention, those skilled in the art will readily recognize a multiplicity of modified and suitable tool fixtures depending upon the needs of the particular application.

[0068] It is contemplated that popup device embodiments of the present invention will be suitable for a wide variety of applications, including, but not limited to, entertainment, utilitarian, marketing, sales. In the preferred embodiment, the popup device has very attractive marketing communication indicia printed on its visible surfaces and, prior to a consumer coming into contact with the device, is stored/transported in its 2D mode, possibly in some other container; such as, without limitation, an outer casing, inserted in a magazine, etc. Then, as the consumer comes into contact with the present device in its 2D mode, the device would either automatically pop open, at least partially, or otherwise invite and/or instruct the consumer to open the device into its 3D mode, thereby peaking the consumer's interest in the novelty of the device, and thereby impressing the marketing message of the marketing communication indicia onto the consumer. By way of example, and not limitation, of one suitable marketing/sales application, the popup device of the present invention could contain a compact disc from an Internet service provider (ISP) and be inserted in its 2D mode into a magazine. Then as the consumer flips through the magazine and reaches the insertion page, the present popup device would spring out from its 2D mode into its 3D mode, thereby serving the CD to the consumer and not only pleasantly surprise the consumer to explore the advertising material, but the consumer would also want to keep the popup device as an attractive, utilitarian desktop disc hold device, which further builds on the marketing impressions made over time. In some variations of the magazine embodiment, the present popup device is inserted and retained in the magazine with a non damaging, relatively weak adhesive

such that when the page is opened, the popup device pops open into its 3D mode, serves the CD, and then releases from the page by way of gravity. In other applications, popup devices according to the present invention may also be sold as an attractive, utilitarian desktop disc hold device with no marketing indicial printed thereupon.

[0069] It is further contemplated that other materials may be stored popup devices according to the present invention. By way of example, and not limitation, instead of holding a CD, other materials, such as marketing materials (e.g., scratch and sniff, scratch and win, etc.) could be stored and served to the consumer upon opening the device into its 3D mode. Other applications of the embodiments of the present invention include, but are not limited to, being a display unit, presenting jewelry, pencils, medals, pictures, and etc. In alternate embodiments of the present invention, a side face of the popup device may be cut out to provide access to the inside empty volume for use as a storage device of larger objects, for example, without limitation a cellular phone, etc.

[0070] Having fully described at least one embodiment of the present invention, other equivalent or alternative methods of implementing a device and advertising method for popup packaging according to the present invention will be apparent to those skilled in the art. The invention has been described above by way of illustration, and the specific embodiments disclosed are not intended to limit the invention to the particular forms disclosed. The invention is thus to cover all modifications, equivalents, and alternatives falling within the spirit and scope of the following claims.

What is claimed is:

1. A packaging device for a flat object, the device comprising:

a flat construction material, said construction material comprising:

a central folding line;

two rectangular areas adjacent to and symmetric with respect to said central folding line, said rectangular areas formed by said central folding line, perpendicular folding lines perpendicular to said central folding line and opposing sides opposing said central folding line, said rectangular areas each having a triangular area formed by said central folding line and triangle folding lines from corners of said rectangular areas to a point on said opposing side;

sidewall section areas formed by said perpendicular folding lines, said opposing sides and said triangle folding lines; and

an object support flap adjacent to each of said sidewall section areas, said object support flaps having right triangular shapes with hypotenuses on respective perpendicular folding lines, said object support flaps each having a right angle cut with respect to and starting near to the base of said object support flaps and ending near or at said respective perpendicular fold lines, thereby delineating a flexing sub-triangle region;

a folded position wherein said object support flaps are folded inward along said perpendicular folding lines and said material is folded along said central folding line such that said object support flaps are contained between said rectangular areas;

an attachment means for attaching opposing sub-triangle regions in said folded position, said attaching providing a storage space for the flat object; and

an unfolded position wherein separation forces separating said rectangular areas fold said sidewall sections inward forming sidewalls of a 3D tetrahedron shape and the flat object can be displayed.

2. The packaging device as recited in claim 1, wherein said object support flaps include locking protrusions on the base and approximate to the right angle, and said central fold line includes slots to receive said locking protrusions in said unfolded position.

3. The packaging device as recited in claim 1, wherein said object support flaps include elastic attachment members for attaching an elastic mechanism between object support flaps on the same side of said central folding line.

4. The packaging device as recited in claim 2, wherein said object support flaps include elastic attachment members for attaching an elastic mechanism between object support flaps on the same side of said central folding line.

5. The packaging device as recited in claim 1, wherein at least one of said triangular areas is formed from inwardly arcing triangle folding lines.

6. The packaging device as recited in claim 1, wherein communication indicia is printed on surfaces of said construction material that are visible in said folded position and said unfolded position.

7. The packaging device as recited in claim 1, wherein the packaging device is stored for transportation in an outer casing.

8. The packaging device as recited in claim 1, wherein said construction material comprising:

trapezoidal areas adjacent each of said object support flaps, said trapezoidal areas formed by extensions of said opposing sides, edges perpendicular to said extensions, and folding lines on a portion of legs of said object support flaps, said trapezoidal areas each having a sub-rectangle area formed by a folding line parallel to said edge; and

a second attachment means for attaching opposing sub-rectangle areas in said folded position, said attaching providing a sleeve for aiding in insertion of the flat object into said storage space.

9. A packaging device for a flat object, the device comprising:

a flat construction material, said construction material comprising:

a central folding line;

two polygon areas adjacent to and symmetric with respect to said central folding line, said polygon areas formed by said central folding line, perpendicular folding lines perpendicular to said central folding line and opposing sides opposing said central folding line, said polygon areas each having a sub-polygon area formed by said central folding line and polygon folding lines from corners of said polygon areas on said central line to said opposing sides;

sidewall section areas formed by said perpendicular folding lines, said opposing sides and said polygon folding lines; and

object support flaps having polygonal shapes with one side on said perpendicular folding line, said object support flaps each having a right angle cut with respect to and starting near to the base of said object support flaps and ending near or at said respective perpendicular fold lines, thereby delineating a flexing sub-triangle region;

a folded flat mode position wherein said object support flaps are folded inward along said perpendicular folding lines and said material is folded along said central folding line such that said object support flaps are contained between said polygon areas;

an attachment means for attaching opposing sub-triangle regions in said folded position, said attaching providing a storage space for the flat object; and

an unfolded position wherein separation forces separating said polygon areas fold said sidewall sections inward forming sidewalls of a 3D polyhedron shape and the flat object is displayed.

10. A packaging device for a flat object, the device comprising:

a flat construction material means for creating fold lines, scores, and cuts on said flat construction material;

a folding means for folding said construction material into a folded position;

an attachment means for attaching parts of said construction material in said folded position; and

an unfolding means for unfolding said construction material into an unfolded 3D position.

11. A method for making a packing device for a flat object, the method comprising the steps of:

using a tool means for creating fold lines, scores, and cuts on a flat construction material;

using a folding means for folding said construction material into a folded position;

using an attachment means for attaching parts of said construction material in said folded position wherein a storage space is created for the flat object and said construction material can be unfolded into a 3D object to present the flat object.

12. A method of advertising/messaging comprising the step of imprinting visible indicia upon the packaging device of claim 1, said indicia being for use in communicating a message to a user of said packaging device.

13. The method of advertising/messaging as recited in claim 12, further comprising the step of inserting the flat object for presentation to said user into said storage space of said packaging device.

14. The method of advertising/messaging as recited in claim 13, further comprising the step of placing said packaging device, in said folded position, within an advertising/messaging medium intended for use by said user, whereby in the course of said user normally accessing said advertising/messaging medium, said packaging device is presented to said user.

15. The method of advertising/messaging as recited in claim 14, further comprising the step of configuring said advertising/messaging medium to cooperate with said packaging device to unfold into said unfolded position so as to present said flat object to said user upon accessing a portion of said advertising/messaging medium where said packaging device is located.

16. The method of advertising/messaging as recited in claim 15, wherein said advertising/messaging medium is a printed publication and said packaging device is inserted in between pages thereof.

17. The method of advertising/messaging as recited in claim 16, wherein said packaging device retained on a page

in said printed publication with a non damaging, relatively weak adhesive such that when said page is opened, said packaging device releases from said page by way of gravity.

18. The method of advertising/messaging as recited in claim 13, wherein said packaging device is stored in an outer casing for transportation to said user.

19. The packing device as recited in claim 10, further comprising a means for placing said packaging device in an outer casing.

20. The method of advertising/messaging as recited in claim 13, wherein said flat object is an information disc.

\* \* \* \* \*